



WAVE

PRISTAL

ICEBERG

OCEAN VIEW

CLEAR

7902: 7-3/4 X 7-3/4 X 3-1/8"  
 7912: 5-3/4 X 7-3/4 X 3-1/8"  
 7922: 5-3/4 X 5-3/4 X 3-1/8"  
 7932: 3-3/4 X 7-3/4 X 3-1/8"  
 9802: 7-3/4 X 7-3/4 X 3-7/8"  
 9812: 5-3/4 X 7-3/4 X 3-7/8"  
 9822: 5-3/4 X 5-3/4 X 3-7/8"  
 9832: 3-3/4 X 7-3/4 X 3-7/8"

7903: 7-3/4 X 7-3/4 X 3-1/8"  
 7913: 5-3/4 X 7-3/4 X 3-1/8"  
 7923: 5-3/4 X 5-3/4 X 3-1/8"  
 7933: 3-3/4 X 7-3/4 X 3-1/8"

7906: 7-3/4 X 7-3/4 X 3-1/8"  
 7916: 5-3/4 X 7-3/4 X 3-1/8"  
 7926: 5-3/4 X 5-3/4 X 3-1/8"  
 7936: 3-3/4 X 7-3/4 X 3-1/8"

7905: 7-3/4 X 7-3/4 X 3-1/8"

7900: 7-3/4 X 7-3/4 X 3-1/8"  
 9800: 7-3/4 X 7-3/4 X 3-7/8"

# MULIA GLASSBLOCK

## ARCHITECTURAL SPECIFICATION



BROMO

DIAMOND

BUBBLE

QUADRA

ICE

7953: 7-3/4 X 7-3/4 X 3-1/8"

7921: 7-3/4 X 7-3/4 X 3-1/8"

7904: 7-3/4 X 7-3/4 X 3-1/8"

7901: 7-3/4 X 7-3/4 X 3-1/8"  
 9801: 7-3/4 X 7-3/4 X 3-7/8"

9852: 7-3/4 X 7-3/4 X 3-1/8"



WAVE END BLOCK  
FINISHING END

7902: 7-3/4 X 7-3/4 X 3-1/8"  
 9802: 7-3/4 X 7-3/4 X 3-7/8"

WAVE ANGLE BLOCK  
Use for both 3-1/8 & 3-7/8 thickness  
ALLOW 90 DEGREE TURNS  
9802-AB

22 DEGREE VARIANT  
9832-VB: 3-3/4 X 7-3/4 X 3-7/8"  
ALLOW 22 AND 45  
DEGREE TURNS

actual size/ nominal size	compressive strength (psi)	weight (lbs.)	shading co-efficient	light transmission	sound level loss (stc)	r-value/ btu
<b>WAVE 3-7/8 THICK</b>						
7-3/4 x 7-3/4 8 x 8 x 4	400-700	5.9	0.655	60	41	1.95 / .51
5-3/4 x 7-3/4 6 x 8 x 4	400-700	5.9	0.655	65	35	1.75 / .55
5-3/4 x 5-3/4 6 x 6 x 4	400-700	5.9	0.655	65	35	1.75 / .55
3-3/4 x 7-3/4 4 x 8 x 4	400-700	5.9	0.655	65	35	1.75 / .55
<b>WAVE 3-7/8 THICK FACE</b>						
7-3/4 x 7-3/4 8 x 8 x 4	400-700	11	0.655	60	50	1.96 / .51
<b>QUADRA 3-7/8 THICK</b>						
7-3/4 x 7-3/4 8 x 8 x 4	400-700	5.9	0.655	60	41	1.95 / .51
<b>ICE (TOBA) 3-7/8 THICK</b>						
7-3/4 x 7-3/4 8 x 8 x 4	400-700	5.9	0.655	59	41	1.95 / .51
<b>WAVE, PRISTAL, ICEBERG 3-1/8 THICK</b>						
7-3/4 x 7-3/4 8 x 8 x 3	400-700	5.3	0.655	65	35	1.95 / .51
5-3/4 x 7-3/4 6 x 8 x 3	400-700	4.4	0.655	65	35	1.75 / .55
3-3/4 x 7-3/4 4 x 8 x 3	400-700	3.2	0.655	65	35	1.75 / .55
5-3/4 x 5-3/4 6 x 6 x 3	400-700	3.0	0.655	65	35	1.75 / .55
<b>QUADRA 3-1/8 THICK</b>						
7-3/4 x 7-3/4 8 x 8 x 3	400-700	5.3	0.655	65	35	1.75 / .55

### MAXIMUM PANEL DIMENSIONS\*

perimeter support method	thick series	thin series
	area (sq. ft.)	area (sq. ft.)
<b>exterior</b>		
channel type restraint	144	85
panel anchors	144	85
channels or panel anchors w/ intermediate stiffener	250	150
<b>interior</b>		
channel type restraint	250	150
panel anchors	250	150

\* uniform building code (ubc) limits height and width to 15 feet.

### WIND LOAD RESISTANCE

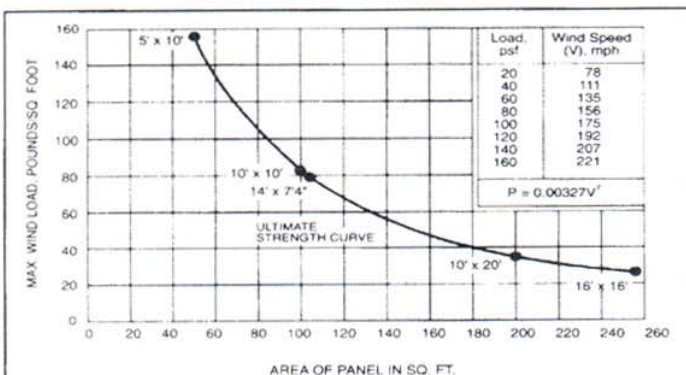

#### HOW TO USE WIND LOAD CHART

Example: If panel desired is 140 sq. ft., review table and you will see the maximum wind load is approximately 52 psf. Maximum exterior panel sizes are based on a design wind load of 20 lbs. per sq. ft. with a 2.7 safety factor.

### NUMBER OF BLOCKS USING FOR 100 SQ. FT. PANEL

block sizes (nominal)	6"	8"	12"	4"x8"	6"x8"
number of blocks	400	225	100	450	300

### INSIDE RADIUS MINIMUMS FOR CURVED PANEL CONSTRUCTION USING SQUARE BLOCKS

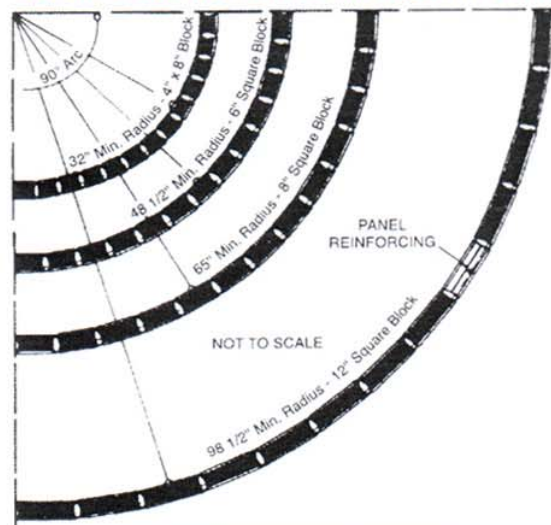

Block size	Inside radius inches	Number of blocks in 90° arc block	Joint thickness in inches	
			inside	outside
4" x 8"	32	13	1/8	5/8
6" x 8"	48 1/2	13	1/8	5/8
8" x 8"	65	13	1/8	5/8
12" x 12"	98 1/2	13	1/8	5/8

# Specification and Installation Guidelines for Mulia Glass Block Products

## Division 4 - Section 04270 Glass Unit Masonry

Mulia Inc. specifications are intended to serve as a guide and are not solely relied upon as the specification source. Considering Mulia Inc. has no control over the installation of the products specified, we therefore assume no potential liability resulting from the application or misapplication of these products.

### • Basic Facts for Installation of Mulia Glass Block:

- A. All types of glass block panels are to be non structural.
- B. The maximum deflection rate for any structural member supporting glass block panels should not exceed L/575.
- C. Where mortar comes in contact with wood, a water base asphalt emulsion should be sufficiently applied and allowed to dry. This creates a contact barrier to which the mortar will adhere.
- D. The heads of all glass block panels must allow for expansion and movement. Mortar must not cross over the expansion spaces. In panels exceeding 25 sq. ft., expansion material must be also used at the jamb locations (refer to details).
- E. Mulia Inc. recommends the use of a **pre-mix white type-s mortar** for all installations that do not require colored mortar. When using colored mortar, the white latex paint should be removed from glass blocks and a colored latex paint that matches the mortar should be applied.
- F. Never use a steel trowel or any other sharp device to tap glass blocks into place. This could cause slight cracks that won't be visible until later! A mallet (of wood, rubber or leather) can be used for this purpose.
- G. Always use a plexiglas striking iron to tool the mortar joints. This protects the mortar joints and will help seal them. Tooling, along with use of an internal type water-repellent, should prevent water leakage from occurring through the mortar joints.
- H. Weather protection also requires use of proper caulking that will adhere to the surfaces at the expansion points.

## PART I GENERAL

### 1.01 Work Included

- A. Mulia Inc. Hollow Glass Block Units
- B. Reinforcing of Joints with Hot-Dipped Steel
- C. Pre-Mix white Type-S Mortar and Required Sealant

### 1.02 Related Work

- A. Jambs, Heads, Lintels and Sills
- B. Anchoring ties or Steel Channels
- C. Required Sealant and Packing Material

### 1.03 References

- A. ASTM C-150 Portland Cement
- B. ASTM C-144 Aggregate for Masonry
- C. ASTM C-153-B2 Zinc (hot dipped) Coatings Applied to Steel

- D. ASTM C-207 Hydrated Lime for Masonry
- E. ASTM C-207 Mortar for Unit Masonry
- F. Underwriters Laboratories Inc. Building Materials 1998 Edition
- G. UL 1 Hour Fire Rating #R18224
- H. ACI 530/ASCE 5/TMS 402 Chapter - 11.3.1 Glass Unit Masonry Design Wind Load Requirements
- I. ASTM E-163 Fire Test Window Assembly
- J. S.B.C.C.I. Testing Requirements
- K. South Florida Testing Requirements  
Miami-Dade Approval NOA #04-0520.02

### 1.04 Product Submittals

- A. Submit Mulia Inc. literature
- B. Submit two samples of desired units

### 1.05 Environmental Concerns at Job Site

- A. Never install glass block units when temperature is at or less than 40 degrees.
- B. Always store glass block units in a clean, dry, cool area that can maintain a temperature not less than 40 degrees 40 hours prior to installation.

## PART II PRODUCTS

### 2.01 Acceptable Manufacturers

- A. Mulia Inc.

### 2.02 Glass Block Units

- A. Shall be hollow units created with a partial vacuum sized to the nominal dimension of \_\_\_\_\_ x \_\_\_\_\_ x \_\_\_\_\_ inches thick.

### 2.03 Accessories

- A. Hot dipped joint panel reinforcing - with a cross wire at 16" on center made out of 9-gauge steel. 1-5/8" width for 3-1/8" blocks or 2" width for 3-7/8" blocks, supplied by Mulia Inc.
- B. Panel anchor ties - 20 gauge hot dipped galvanized steel perforated strips that are 24" long and 1-3/4" wide to be supplied by Mulia Inc.
- C. Expansion strips - 3-1/2" wide x 3/4" thick polyethylene foam, supplied by Mulia.
- D. Asphalt emulsion - Karnak 100 or equal (1-800-526-4236)
- E. Sealant - Urethane or silicone caulk recommended by Sealant Manufacturer.
- F. Backer Rod - As suggested by Sealant Manufacturer.

### 2.04 Mortar Materials

- A. Use a Type-S Mortar as described in ASTM C-270, should have 1 part white Portland cement, 3/4 parts of fine white sand that can pass through a #8 sieve. Make sure the sand is free from iron contaminants which could cause stains. Do not retemper mortar, mix only as needed.
- B. Internal type waterproofer - Laticrete 850 by Laticrete (1-800-777-9235) or Hydrocide Powder by Sonneborn Building Products (1-800-422-1902).

- C. Plexiglas striking irons - Seal mortar joints by tooling with Plexiglas striking iron, so as not to burn the white mortar joints, while providing a smooth concave water-protected face.

## PART III EXECUTION

### 3.01 Preparation

- A. Establish that all components needed are on-site and installed properly.
- B. Prepare mortar for use by only mixing the amount that can be used within 1 hour. Never add any antifreezes or accelerators.

### 3.02 Installation

- A. Verify opening is sized and ready for proper installation. When using panel anchor ties assembly, a minimum 1/2" wider than nominal size and 1/2" taller than nominal size should be sufficient if joints are uniform. C-Channel assembly must allow for the thickness of steel.
- B. Place asphalt emulsion on sill area and allow to dry.
- C. Attach all panel expansion materials and panel anchor ties as needed to panel heads and jambs.
- D. Place mortar onto sill creating a bed joint. Make sure bed joint is full.
- E. Level first course of blocks while maintaining a joint of 1/4" width plus or minus 1/8".
- F. Install second bed joint full of mortar, do not furrow! Gently push panel reinforcing into the middle of mortar.
- G. Install the second row of glass blocks leveling and maintaining full, uniform joints. When panel anchor ties are being used, install at 16" on center at the jambs and head locations. Overlay panel reinforcing horizontally, with a 6" overlap from the panel anchor ties that are attached to the jambs. Repeat this installation process every 16" in the height of your panel. If using channel construction, panel reinforcing is needed horizontally for every 16" of height only.
- H. The head joint should be free from all mortar to allow for the sealant desired.
- I. Strike all mortar joints with plexiglas striking iron when joints are fingerprint hard.
- J. After 24 hours setup, install all packing material and sealant pursuant to manufacturer recommendations.

### 3.03 Cleaning

- A. Remove excess mortar squeezed out while laying glass block. At the time the joints are being struck use a dry cloth or burlap to remove excess smears on the face of the block.
- B. Never use acids or abrasive cleaners on glass block.
- C. Sealant excess should be removed according to sealant manufacturer directions.
- D. Use the finest of steel wool (no larger than a #4 size is appropriate) to remove any excess mortar off the face of the glass block. This is recommended for hard to remove spots only, not an overall cleaning!

# Typical Head Details

## Exterior Openings

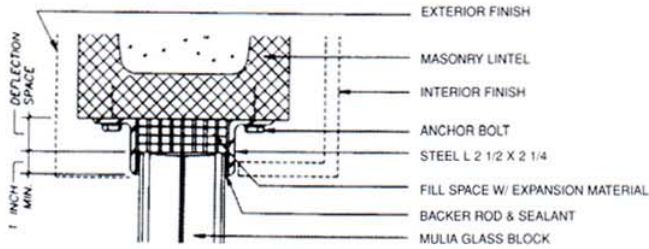

Head - Detail of Glass Block in Masonry Wall

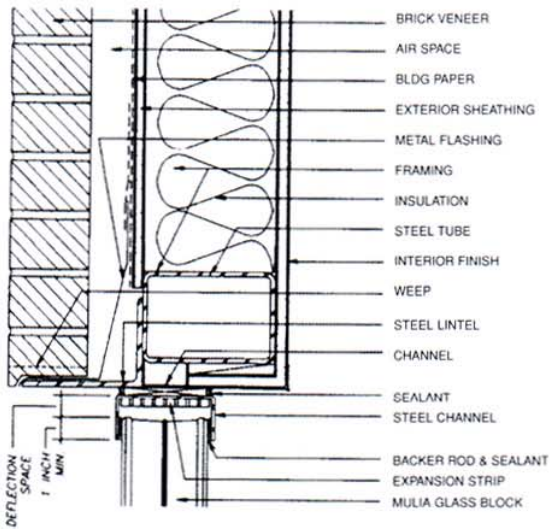

Head - Detail of Glass Block in Steel Stud Wall

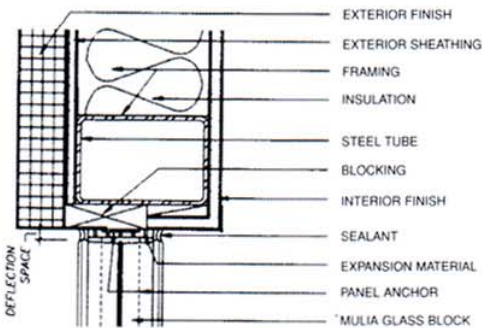

Head - Detail of Glass Block in Steel Stud Wall

# Typical Jamb Details

## Exterior Openings

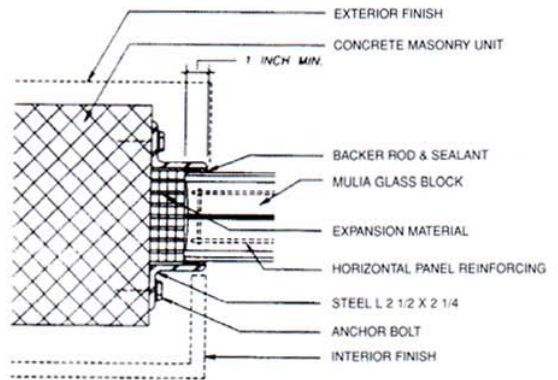

Jamb - Detail of Glass Block in Masonry Wall

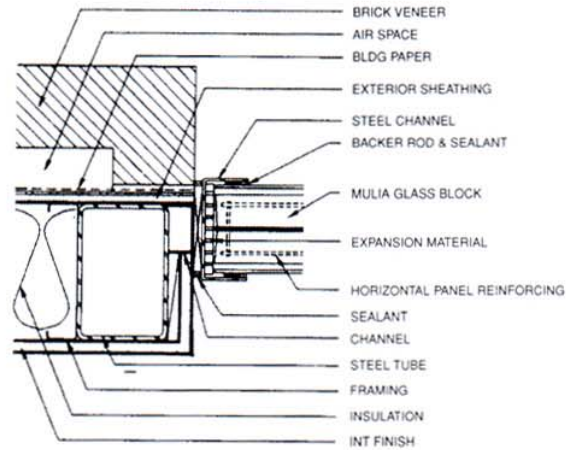

Jamb - Detail of Glass Block in Steel Stud Wall

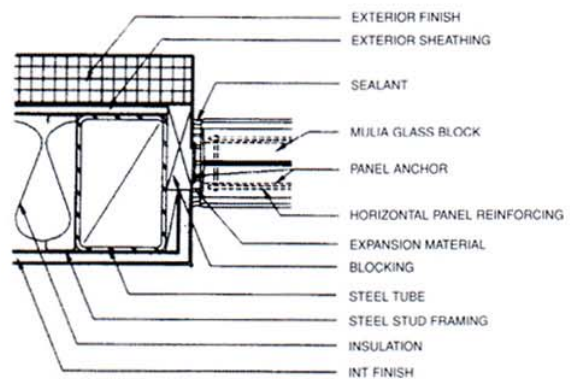

Jamb - Detail of Glass Block in Steel Stud Wall

# Typical Mortared Stiffener Details

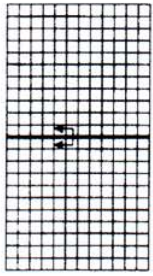

HORIZONTAL DIVIDER

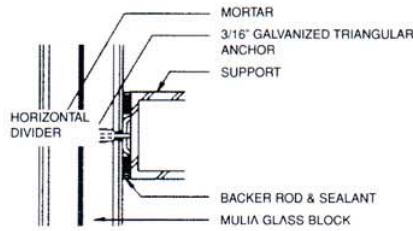

Horizontal Support in Glass Block Panel

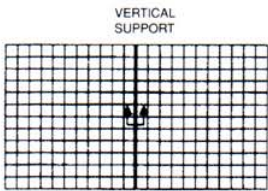

VERTICAL SUPPORT

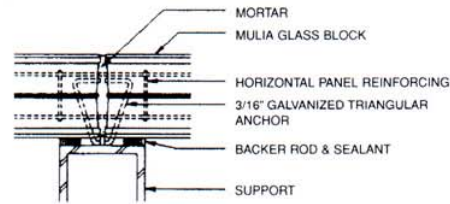

Vertical Divider in Glass Block Panel

All Panels using Vertical Dividers should not exceed 10 ft. in height.

# Corner Detail

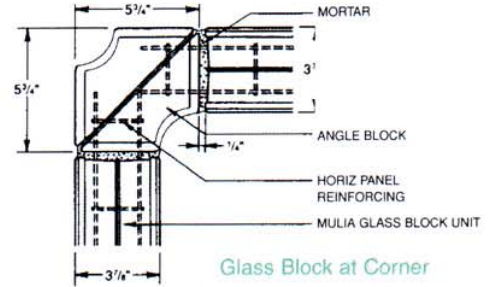

Glass Block at Corner

# 22 Degree Arch Detail

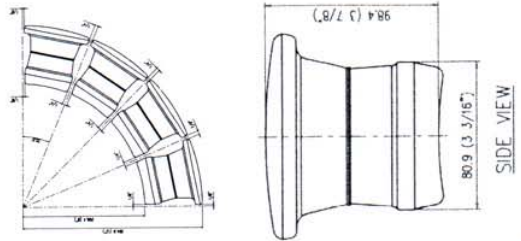

# Typical Stiffener Details

## Continuous Panels

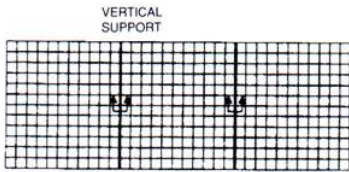

VERTICAL SUPPORT

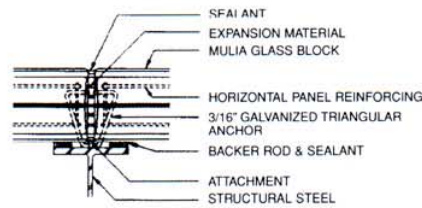

Vertical Support between Horizontal Panels

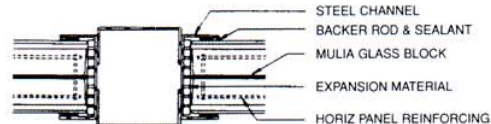
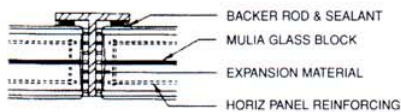
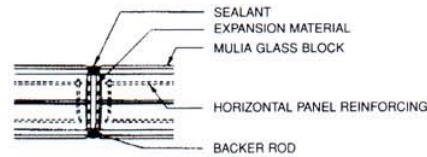

Jamb - Detail of Steel Dividers between Horizontal Panels

All Panels using Vertical Dividers should not exceed 10 ft. in height.

Details shown are available in CAD, call Mulia for further information.

# Interior Details

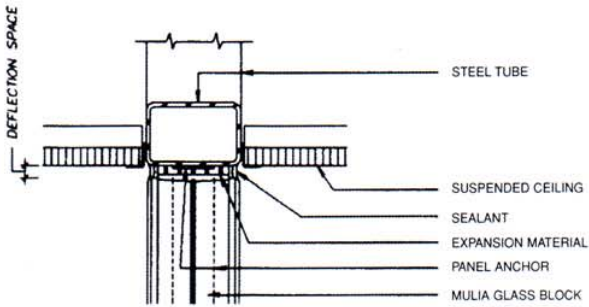

Head - Detail of Glass Block at Suspended Ceiling

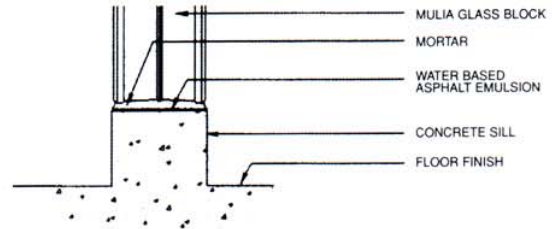

Sill - Detail of Interior Concrete floor Slab

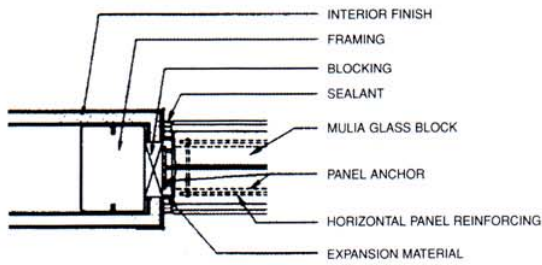

Jamb - Detail of Glass Block in Partition

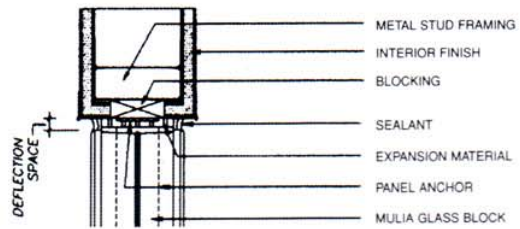

Jamb - Detail of Glass Block in Partition

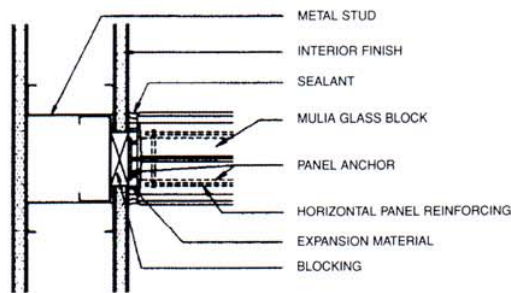

Jamb - Detail of Glass Block Perpendicular to Partition

# Typical Shelf Angle Details

## Continuous Panels

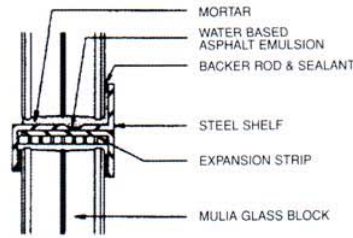
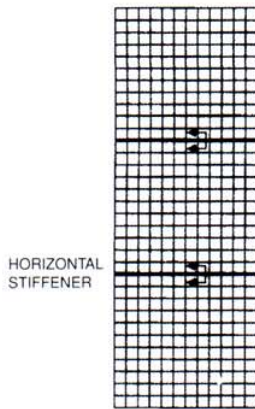

Structural Steel Dividers between Vertical Panels

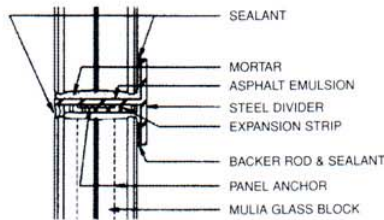

Finishing End

## Panel Anchor Construction

## Channel Anchor Construction

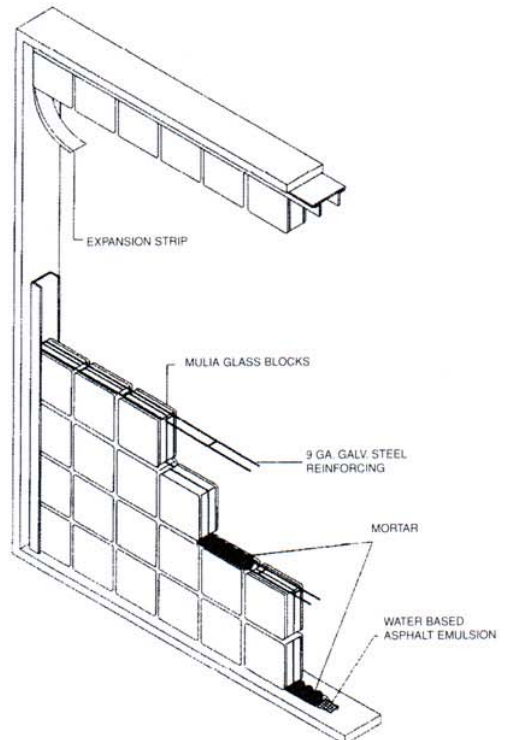
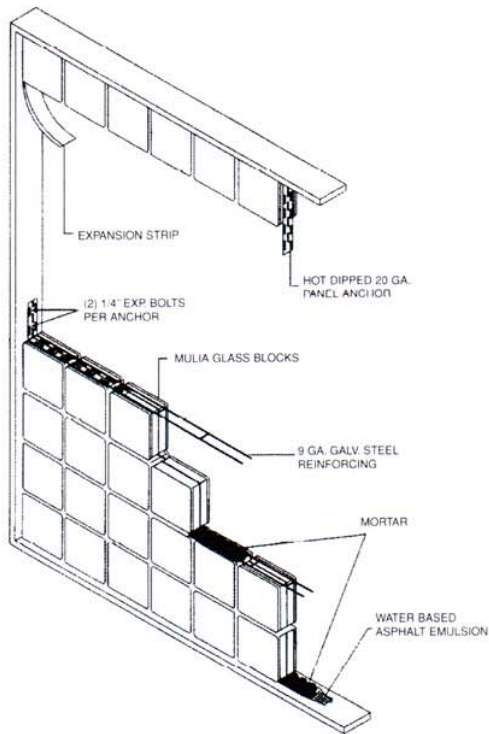

Details shown are available in CAD, call Mulia for further information.

## Hollow Metal Door Frame Details

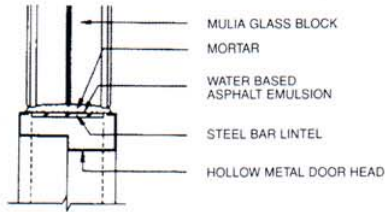

Head - Hollow Metal Door Frame at Glass Block

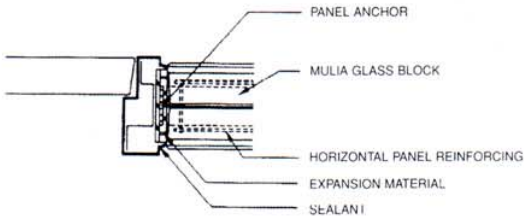

Jamb - Hollow Metal Door Frame at Glass Block

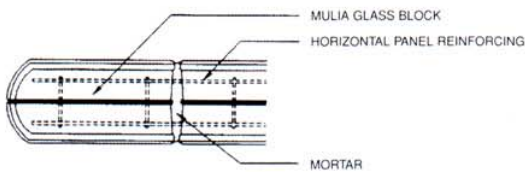

Finishing End

## Typical Sill Details

### Exterior Openings

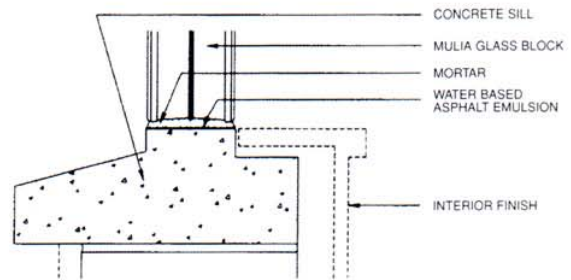

Sill - Detail of Glass Block in CMU Wall

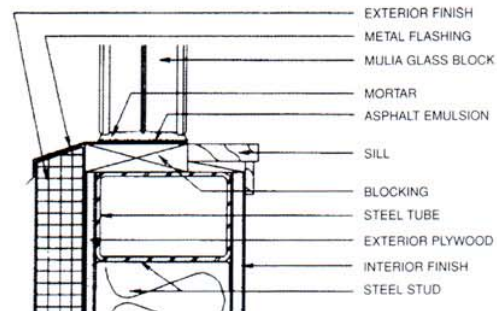

Sill - Detail of Glass Block in Steel Stud Wall

Details shown are available in CAD, call Mulia for further information.

## Five-Year Limited Warranty

Mulia warrants its first quality glass block products to be free from manufacturing defects for a period of five years from the date of purchase. If a product is found to be defective, Mulia will supply new products of the same similar grade (at the manufacturer's discretion) sufficient to repair or replace the defective materials. Mulia does NOT warrant installers workmanship and will not replace blocks damaged as a result of faulty installation.

Mulia glass block should be professionally installed by contractors who have demonstrated expertise in installing this product. Workmanship errors should be addressed to the installation contractor. EXCLUDED ARE EXPRESSED OR IMPLIED WARRANTIES OF ANY KIND, INCLUDING THOSE OF MERCHANTABILITY OR FITNESS FOR A PARTICULAR PURPOSE RELATING TO THE PERFORMANCE OF AN INSTALLATION containing Mulia glass block. In no event shall Mulia be held liable for labor, lost profits or any other indirect, incidental, special, consequential or punitive damages resulting from defective products or installation, regardless of the theory of liability upon which any such damages are claimed.

Also excluded from warranty are the following situations:

- Dissatisfaction due to improper maintenance or installation with materials and adhesives that are not recommended by Mulia.
- Products sold as non-regulars, irregulars or not first quality.
- Products installed with an obvious defect visible prior to installation.

The only remedy available is replacement of defective blocks, excluding labor. Some states do not allow limitations or exclusions of incidental or consequential damages or limitations on length of implied warranties, so specific rights may vary from state to state.

If a defect is discovered, send written notice to Mulia Inc., 14820 Carmenita Road, Unit A, Norwalk, CA 90750. Include proof of purchase, a sample of a defective block if possible, and photographs of the installation. Upon receipt of these items, Mulia will investigate the claim and replace any block found to be defective.

The information contained in this brochure is accurate and reliable based upon facts available at the time of printing.

14820 Carmenita Road, Unit A  
Norwalk, CA 90750  
Toll Free: (888) 888-9099  
Tel: (562) 345-2788  
Fax: (562) 345-2700

